

REVISIONS				
CHANGE ORDER	LTR	DESCRIPTION	DATE	APPROVED
Q08023	1	PAG 46 was PAG 100	10/01/08	
Q09035	2	ADDED TOLERANCES & PART NO'S	09/22/09	
Q11002	3	RELOCATED PRV	03/16/11	

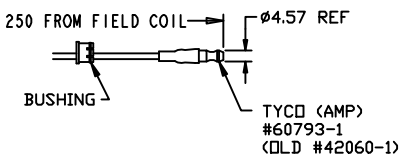

TERMINAL LEAD DETAIL

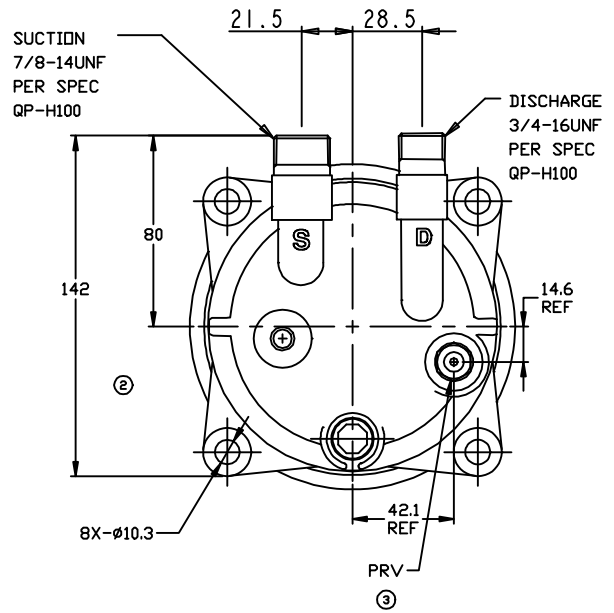
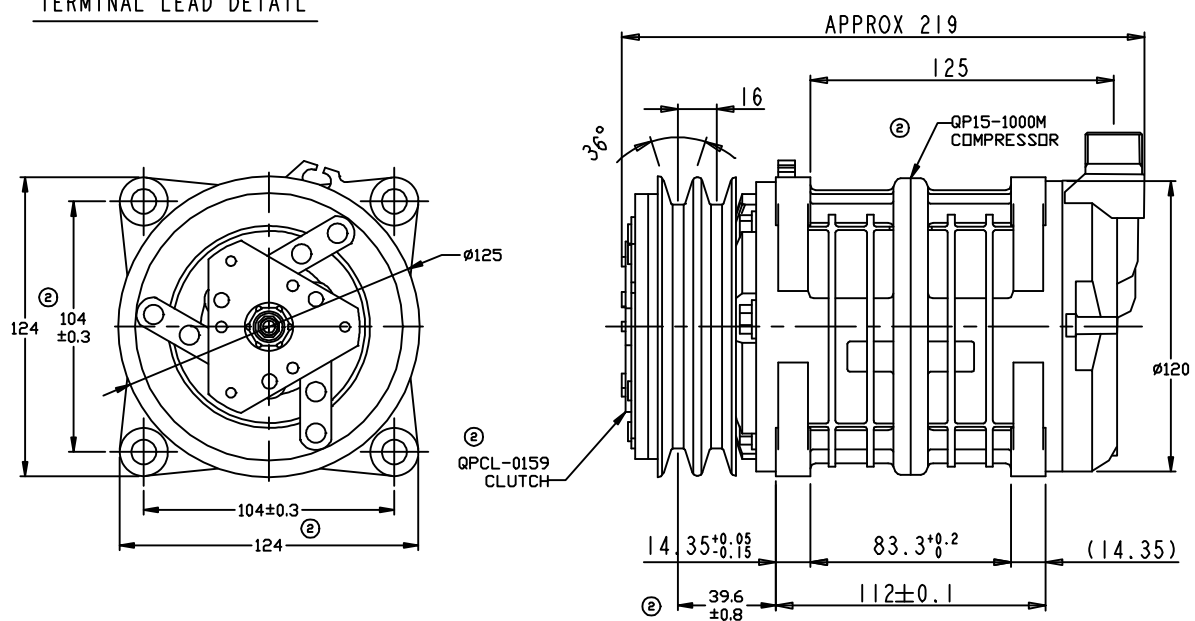

- CLUTCH SPECIFICATIONS:
- VOLTAGE.....12 VDC
  - BELT.....A2
  - STATIC TORQUE  
 INITIAL.....35 Nm (3.5 Kgfm)  
 AFTER BURNISHING.....49 Nm (5 Kgfm)
  - MAX POWER CONSUMPTION.....45W @ 25°C
  - ROTATION DIRECTION.....CW OR CCW
  - WEIGHT.....2.30 Kg

- COMPRESSOR SPECIFICATIONS:
- MODEL.....QP15HD
  - NUMBER OF CYLINDERS.....6
  - BORE X STROKE.....36 X 24.0 mm
  - DISPLACEMENT.....146.7 cm<sup>3</sup>/REV
  - SPEED RANGE.....700 - 6000 RPM
  - ROTATION DIRECTION.....CW OR CCW
  - REFRIGERANT.....R-134a
  - LUBRICANT.....PAG 46 150+20cm<sup>3</sup> ①
  - WEIGHT.....4.6 Kg

THIRD ANGLE PROJECTION 	UNLESS OTHERWISE SPECIFIED DIMENSIONS ARE IN MM. INTERPRET DIM AND TOL PER ASME Y14.5M - 1994		CAD GENERATED DRAWING, DO NOT MANUALLY UPDATE	
	DRAWN	GLB	DATE	11/08/07
	CHECKED			
	APPROVED			
FINISH		ENG APPVL		

**QUE PRODUCTS, LLC**  
 DECATUR, ILLINOIS

TITLE  
 COMPRESSOR ASSEMBLY  
 QP15HD V-3/4 7/8 MOND HEAD  
 A2 125mm 12V LEAF SPRING

SIZE A	CODE IDENT NO	DWG NO	QP15-1161	REV 3
SCALE NONE		SHEET 1 OF 1		